



Your Global Flow Control Partner



Bray/McCannalok High Performance Butterfly Valves Technical Manual



ABS
FOUNDED 1862



TABLE OF CONTENTS

Seating & Unseating Torques1
ASME 150 - Torques (Lb-in)2
ASME 150 - Torques (Lb-in)3
ASME 300 - Torques (Lb-in)4
ASME 600 - Torques (Lb-in)5
ASME 150 - Torques (N-m)6
ASME 150 - Torques (N-m)7
ASME 300 - Torques (N-m)8
ASME 600 - Torques (N-m)9
Dynamic Torques	10
Dynamic Torque Coefficient	11
Subchoked and Choked Flow	12
Subchoked Liquid Flow, Line-size Valve	13
Choked Gas Flow, Reduced-size Valve	13
Maximum Allowable Stem Torques (Lb-in)*	14
Maximum Allowable Stem Torques (N-m)*	15
Valve Sizing Coefficients (Cv)	16
ASME 150 Series 40/41/4A - Valve Sizing Coefficient (Cv)	16
ASME 300 Series 42/43/4B - Valve Sizing Coefficient (Cv)	17
ASME 600 Series 44/45 - Valve Sizing Coefficient (Cv)	17
Valve Sizing Coefficients (Kv)	18
ASME 150 Series 40/41/4A - Valve Sizing Coefficient (Kv)	18
ASME 300 Series 42/43/4B - Valve Sizing Coefficient (Kv)	19
ASME 600 Series 44/45 - Valve Sizing Coefficient (Kv)	19
Pressure-Temperature Charts - Standard McCannalok Valves	20
Pressure-Temperature Charts - Firesafe McCannalok Valves	22
Pressure Temperature Charts - Cryogenic McCannalok Valves	23
Examples of Typical Flange to Valve Bolting	25

For information on this product and other Bray products please visit us at our web page - www.bray.com

SEATING & UNSEATING TORQUES

Valve orientation to the flow of media affects the torque.
Torque values are presented in two categories:

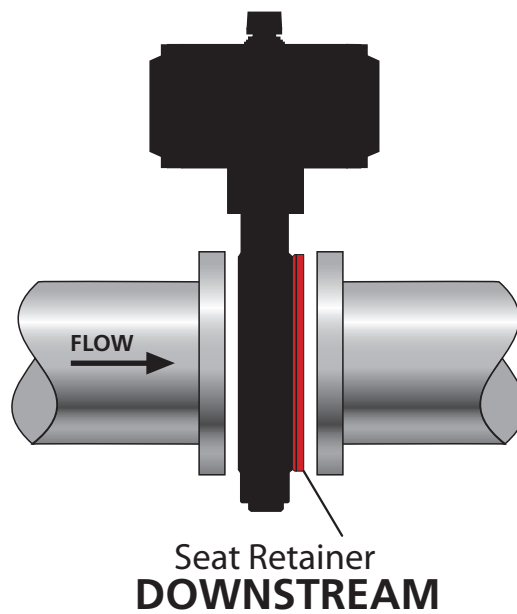
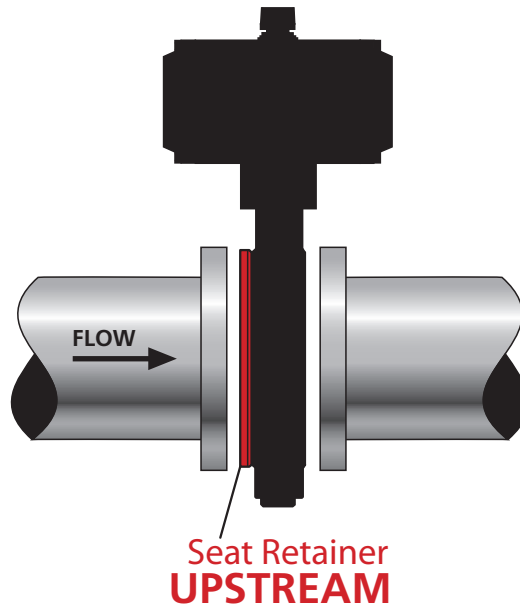

ASME 150 - Torques (Lb-in)								
Series 40/41/4A Standard - Valve Differential Pressure (psig)								
Valve Size Inches	Less than 150 psig		>150-200 psig		>200-250 psig		>250-285 psig	
	Retainer Upstream	Retainer Downstream	Retainer Upstream	Retainer Downstream	Retainer Upstream	Retainer Downstream	Retainer Upstream	Retainer Downstream
2	Please Consult Factory							
2.5	170	200	190	240	210	280	215	300
3	185	220	210	260	225	300	230	320
4	275	320	300	370	315	420	320	460
5	550	650	640	800	705	940	730	1,040
6	690	810	770	960	825	1,100	840	1,200
8	1,280	1,500	1,400	1,700	1,500	1,950	1,570	2,100
10	2,400	2,800	2,640	3,300	2,820	3,760	2,870	4,100
12	3,500	4,100	4,000	5,000	4,400	5,900	4,550	6,500
14	5,400	6,300	5,920	7,400	6,400	8,500	6,650	9,500
16	7,700	9,100	9,040	11,300	10,100	13,500	10,500	15,000
18	11,900	14,000	13,600	17,000	15,000	20,000	15,400	22,000
20	15,300	18,000	17,100	21,300	18,500	24,700	18,900	27,000
24	24,650	29,000	27,680	34,600	30,000	40,100	30,800	44,000
26	24,650	29,000	27,680	34,600	30,000	40,100	30,800	44,000
28	34,850	41,000	37,600	47,000	44,300	59,200	44,500	63,500
30	39,950	47,000	42,960	53,700	50,800	67,700	52,500	75,000
32	45,000	53,000	48,800	61,000	57,600	76,800	58,800	84,000
34	45,000	53,000	48,800	61,000	57,600	76,800	58,800	84,000
36	54,000	64,000	64,800	81,000	73,500	98,000	77,000	110,000
40	62,000	73,000	73,600	92,000	82,500	110,000	84,700	121,000
42	71,000	83,000	84,000	105,000	95,250	127,000	101,000	143,000
48	98,000	115,000	121,600	152,000	142,500	190,000	151,900	217,000
54	136,000	160,000	169,600	212,000	198,000	265,000	211,400	302,000
60	Please Consult Factory							

ASME 150 - Torques (Lb-in)								
Series 40/41/4A Fire Safe - Valve Differential Pressure (psig)								
Valve Size Inches	Less than 150 psig		>150-200 psig		>200-250 psig		>250-285 psig	
	Retainer Upstream	Retainer Downstream	Retainer Upstream	Retainer Downstream	Retainer Upstream	Retainer Downstream	Retainer Upstream	Retainer Downstream
2.5	680	720	690	770	700	810	710	840
3	750	800	760	830	770	870	780	900
4	850	900	880	980	890	1,050	910	1,100
5	1,420	1,500	1,470	1,630	1,500	1,750	1,600	1,850
6	1,660	1,750	1,690	1,880	1,800	2,000	1,900	2,100
8	2,600	2,800	2,690	2,950	2,750	3,100	2,860	3,200
10	3,900	4,200	4,100	4,530	4,250	4,860	4,400	5,100
12	6,500	6,900	6,600	7,350	6,700	7,790	6,900	8,100
14	12,300	13,000	12,600	14,000	13,200	15,500	13,600	17,000
16	15,200	16,000	15,800	17,600	16,300	19,200	16,320	20,400
18	18,000	19,000	18,900	21,000	19,000	22,500	19,200	24,000
20	21,800	23,000	22,500	25,000	23,800	28,000	28,800	36,000
24	31,000	33,000	34,200	38,000	37,400	44,000	50,400	63,000
26	Please Consult Factory							
28								
30								
32								
34								
36								
40								
42								
Series 40/41/4A Metal Seated - Valve Differential Pressure (psig)								
2.5	614	646	624	694	631	727	640	758
3	674	723	683	745	689	781	702	815
4	765	814	790	877	800	947	821	996
5	1,271	1,347	1,320	1,474	1,350	1,579	1,445	1,669
6	1,496	1,582	1,528	1,700	1,615	1,806	1,701	1,884
8	2,343	2,509	2,432	2,661	2,489	2,781	2,563	2,886
10	3,502	3,772	3,711	4,077	3,808	4,369	3,982	4,585
12	5,863	6,176	5,966	6,652	6,030	7,003	6,189	7,266
14	11,119	11,752	11,403	12,614	11,946	14,012	12,294	15,368
16	13,726	14,368	14,220	15,928	14,735	17,299	14,770	18,380
18	16,236	17,043	17,067	18,816	17,195	20,363	17,338	21,672
20	19,685	20,723	20,340	22,575	21,491	25,116	25,834	32,364
24	27,962	29,865	30,746	34,276	33,585	39,600	45,108	56,700
30	Please Consult Factory							

ASME 300 - Torques (Lb-in)								
Series 42/43/4B Standard - Valve Differential Pressure (psig)								
Valve Size Inches	Less than 150 psig		>150-350 psig		>350-550 psig		>550-740 psig	
	Retainer Upstream	Retainer Downstream	Retainer Upstream	Retainer Downstream	Retainer Upstream	Retainer Downstream	Retainer Upstream	Retainer Downstream
2.5	170	200	290	360	380	510	470	670
3	185	220	310	380	400	530	490	690
4	270	320	420	530	550	730	700	1,000
5	550	650	1,000	1,250	1,390	1,850	1,800	2,550
6	850	1,000	1,320	1,650	1,720	2,300	2,100	3,000
8	1,580	1,850	2,480	3,100	3,230	4,300	3,700	5,300
10	2,800	3,300	4,400	5,500	5,700	7,600	7,000	10,000
12	4,250	5,000	6,640	8,300	8,630	11,500	10,500	15,000
14	7,300	8,600	10,720	13,400	13,700	18,300	15,400	22,000
16	11,900	14,000	17,200	21,500	21,800	29,000	26,600	38,000
18	15,300	18,000	21,600	27,000	27,100	36,100	31,500	45,000
20	20,400	24,000	29,400	36,700	37,000	49,300	42,700	61,000
24	32,300	38,000	45,600	57,000	57,500	76,700	66,500	95,000
30	68,000	80,000	101,600	127,000	129,000	172,000	147,000	210,000
36	101,150	119,000	144,000	180,000	180,000	240,000	203,000	290,000
40	115,600	136,000	168,000	210,000	222,000	296,000	278,600	398,000
48	127,500	150,000	217,600	272,000	321,000	428,000	403,200	576,000
54	Please Consult Factory							
Series 42/43/4B Fire Safe - Valve Differential Pressure (psig)								
2.5	680	720	775	860	860	1,010	880	1,100
3	750	800	855	950	935	1,100	960	1,200
4	850	900	1,080	1,200	1,275	1,500	1,360	1,700
5	1,420	1,500	2,070	2,300	2,635	3,100	2,880	3,600
6	2,000	2,100	2,610	2,900	3,150	3,700	3,440	4,300
8	3,000	3,150	3,870	4,300	4,675	5,500	4,960	6,200
10	6,900	7,300	9,180	10,200	11,050	13,000	12,000	15,000
12	10,450	11,000	13,200	14,700	15,640	18,400	16,800	21,000
14	18,050	19,000	21,600	24,000	22,100	26,000	22,400	28,000
16	26,600	28,000	34,200	38,000	37,400	44,000	39,200	49,000
18	Please Consult Factory							
20	Please Consult Factory							
24	Please Consult Factory							
30	Please Consult Factory							
36	Please Consult Factory							
Series 42/43/4B Metal Seated - Valve Differential Pressure (psig)								
2.5	611	650	700	771	776	905	795	990
3	674	721	766	852	837	993	869	1,080
4	768	812	870	1,082	1,150	1,353	1,228	1,525
5	1,277	1,356	1,867	2,061	2,372	2,787	2,601	3,247
6	1,792	1,884	2,354	2,622	1,939	3,330	3,106	3,849
8	2,712	2,822	3,479	3,892	4,193	4,961	4,454	5,586
10	6,245	6,607	8,234	9,200	9,923	11,648	10,752	13,470
12	9,405	9,845	11,840	13,304	14,076	16,523	15,170	19,005
14	16,191	17,081	19,440	21,720	19,824	23,452	20,115	25,116
16	24,020	25,284	30,917	34,352	33,510	39,424	35,476	44,198
18	Please Consult Factory							
20	Please Consult Factory							
24	Please Consult Factory							
30	Please Consult Factory							

ASME 600 - Torques (Lb-in)								
Series 44/45 Standard - Valve Differential Pressure (psig)								
Valve Size Inches	Less than 150 psig		>150-600 psig		>600-1050 psig		>1050-1480 psig	
	Retainer Upstream	Retainer Downstream	Retainer Upstream	Retainer Downstream	Retainer Upstream	Retainer Downstream	Retainer Upstream	Retainer Downstream
3	400	480	700	870	900	1,200	1,000	1,450
4	850	960	1,280	1,600	1,580	2,100	1,900	2,700
6	1,450	1,700	2,560	3,200	3,450	4,600	4,100	5,800
8	3,500	4,100	5,760	7,200	7,600	10,100	9,800	14,000
10	7,100	8,300	9,600	12,000	13,500	18,000	16,800	24,000
12	10,100	11,800	11,200	14,000	19,500	26,000	21,000	30,000
14	11,900	14,000	19,200	24,000	24,800	33,000	30,000	43,000
16	14,000	16,500	28,400	35,500	34,500	46,000	45,500	65,000
18	16,200	19,000	34,400	43,000	49,000	65,000	64,400	92,000
20	21,300	25,000	45,600	57,000	66,000	88,000	87,000	124,000
24	33,000	39,000	71,000	89,000	94,000	125,000	123,000	175,000
30	71,000	83,000	137,000	172,000	180,000	240,000	217,000	310,000
Series 44/45 Fire Safe - Valve Differential Pressure (psig)								
3	Please Consult Factory							
4								
6								
8								
10								
12								
14								
16								
Series 44/45 Metal Seated - Valve Differential Pressure (psig)								
3	Please Consult Factory							
4								
6								
8								
10								
12								
14								
16								

ASME 150 - Torques (N-m)								
Series 40/41/4A Standard - Valve Differential Pressure (Bar)								
Valve Size mm	Less than 10.3 Bar		>10.3-14 Bar		>14-17.2 Bar		>17.2-20 Bar	
	Retainer Upstream	Retainer Downstream	Retainer Upstream	Retainer Downstream	Retainer Upstream	Retainer Downstream	Retainer Upstream	Retainer Downstream
50	Please Consult Factory							
65	19	23	21	27	24	32	24	34
80	21	25	24	29	25	34	26	36
100	31	36	34	42	36	47	36	52
125	62	73	72	90	80	106	82	118
150	78	92	87	108	93	124	95	136
200	145	170	158	192	170	220	177	237
250	271	316	411	373	319	425	324	463
300	396	463	452	565	497	667	514	735
350	610	712	669	836	723	961	751	1,074
400	870	1,028	1,022	1,277	1,141	1,526	1,187	1,695
450	1,345	1,582	1,537	1,921	1,695	2,260	1,740	2,486
500	1,729	2,034	1,932	2,407	2,091	2,791	2,136	3,051
600	2,785	3,277	3,128	3,910	3,390	4,531	3,480	4,972
650	2,785	3,277	3,128	3,910	3,390	4,531	3,480	4,972
700	3,938	4,633	4,249	5,311	5,006	6,690	5,029	7,176
750	4,514	5,311	4,854	6,068	5,740	7,650	5,933	8,475
800	5,085	5,989	5,514	6,893	6,509	8,678	6,644	9,492
850	5,085	5,989	5,514	6,893	6,509	8,678	6,644	9,492
900	6,102	7,232	7,322	9,153	8,306	11,074	8,701	12,430
1,000	7,006	8,249	8,317	10,396	9,323	12,430	9,571	13,673
1,050	8,023	9,379	9,492	11,865	10,763	14,351	11,413	16,159
1,200	11,074	12,995	13,741	17,176	16,103	21,470	17,165	24,521
1,350	15,368	18,080	19,165	23,956	22,374	29,945	23,888	34,126
1,500	Please Consult Factory							

ASME 150 - Torques (N-m)																
Series 40/41/4A Fire Safe - Valve Differential Pressure (Bar)																
Valve Size mm	Less than 10.3 Bar		>10.3-14 Bar		>14-17.2 Bar		>17.2-20 Bar									
	Retainer Upstream	Retainer Downstream	Retainer Upstream	Retainer Downstream	Retainer Upstream	Retainer Downstream	Retainer Upstream	Retainer Downstream								
65	77	81	78	87	79	92	80	95								
80	85	90	86	94	87	98	88	102								
100	96	102	99	111	101	119	103	124								
125	160	170	166	184	170	198	181	209								
150	188	198	191	212	203	226	215	237								
200	294	316	304	333	311	350	323	362								
250	441	475	463	512	480	549	497	576								
300	735	780	746	831	757	880	780	915								
350	1,390	1,469	1,424	1,582	1,492	1,752	1,537	1,921								
400	1,718	1,808	1,785	1,989	1,842	2,170	1,844	2,305								
450	2,034	2,147	2,136	2,373	2,147	2,543	2,170	2,712								
500	2,463	2,599	2,543	2,825	2,689	3,164	3,254	4,068								
600	3,503	3,729	3,865	4,294	4,226	4,972	5,695	7,119								
650	Please Consult Factory															
700																
750																
800																
850																
900																
1,000																
1,050																
Series 40/41/4A Metal Seated - Valve Differential Pressure (Bar)																
65									69	73	71	78	71	82	72	86
80	76	82	77	84	78	88	79	92								
100	86	92	89	99	90	107	93	112								
125	144	152	149	166	153	178	163	189								
150	169	179	173	192	182	204	192	213								
200	265	283	275	301	281	314	290	326								
250	396	426	419	461	430	494	450	518								
300	662	698	674	752	681	791	699	821								
350	1,256	1,328	1,288	1,425	1,350	1,583	1,389	1,736								
400	1,551	1,623	1,607	1,800	1,665	1,955	1,669	2,077								
450	1,834	1,926	1,928	2,126	1,943	2,301	1,959	2,449								
500	2,224	2,341	2,298	2,551	2,428	2,838	2,919	3,657								
600	3,159	3,374	3,474	3,873	3,795	4,474	5,097	6,406								
750	Please Consult Factory															

ASME 300 - Torques (N-m)								
Series 42/43/4B Standard - Valve Differential Pressure (Bar)								
Valve Size mm	Less than 10.3 Bar		>10.3-24 Bar		>24-38 Bar		>38-51 Bar	
	Retainer Upstream	Retainer Downstream	Retainer Upstream	Retainer Downstream	Retainer Upstream	Retainer Downstream	Retainer Upstream	Retainer Downstream
65	19	23	33	41	43	58	53	76
80	21	25	35	43	45	60	55	78
100	31	36	47	60	62	82	79	113
125	62	73	113	141	157	209	203	288
150	96	113	149	186	194	260	237	339
200	179	209	280	350	365	486	418	599
250	316	373	497	622	644	859	791	1,130
300	480	565	750	938	975	1,300	1,187	1,695
350	825	972	1,211	1,514	1,548	2,068	1,740	2,486
400	1,345	1,582	1,944	2,430	2,463	3,277	3,006	4,294
450	1,729	2,034	2,441	3,051	3,062	4,079	3,560	5,085
500	2,305	2,712	3,322	4,147	4,181	5,571	4,825	6,893
600	3,650	4,294	5,153	6,441	6,498	8,667	7,515	10,735
750	7,684	9,040	11,481	14,351	14,577	19,436	16,611	23,730
900	11,430	13,447	16,272	20,340	20,340	27,120	22,939	32,770
1,000	13,063	15,368	18,984	23,730	25,086	33,448	31,482	44,974
1,200	14,408	16,950	24,589	30,736	36,273	48,364	45,562	65,088
1,350	Please Consult Factory							
Series 42/43/4B Fire Safe - Valve Differential Pressure (Bar)								
65	77	81	88	97	97	114	99	124
80	85	90	97	107	106	124	108	136
100	96	102	122	136	144	170	154	192
125	160	170	234	260	298	350	325	407
150	226	237	295	328	356	418	389	486
200	339	356	437	486	528	622	560	701
250	780	825	1,037	1,153	1,249	1,469	1,356	1,695
300	1,181	1,243	1,492	1,661	1,767	2,079	1,898	2,373
350	2,040	2,147	2,441	2,712	2,497	2,938	2,531	3,164
400	3,006	3,164	3,865	4,294	4,226	4,972	4,430	5,537
450	Please Consult Factory							
500	Please Consult Factory							
600	Please Consult Factory							
750	Please Consult Factory							
900	Please Consult Factory							
Series 42/43/4B Metal Seated - Valve Differential Pressure (Bar)								
65	69	73	79	87	88	102	90	112
80	76	81	87	96	95	112	98	122
100	87	92	110	122	130	153	139	172
125	144	153	211	233	268	315	294	367
150	202	213	266	296	219	376	351	435
200	306	319	393	440	474	561	503	631
250	706	746	930	1,040	1,121	1,316	1,215	1,522
300	1,063	1,112	1,338	1,503	1,590	1,867	1,714	2,147
350	1,829	1,930	2,196	2,454	2,240	2,650	2,273	2,838
400	2,714	2,857	3,493	3,881	3,786	4,454	4,008	4,994
450	Please Consult Factory							
500	Please Consult Factory							
600	Please Consult Factory							
700	Please Consult Factory							

ASME 600 - Torques (N-m)								
Series 44/45 Standard - Valve Differential Pressure (Bar)								
Valve Size mm	Less than 10.3 Bar		>10.3-41.4 Bar		>41.4-72.4 Bar		>72.4-102 Bar	
	Retainer Upstream	Retainer Downstream	Retainer Upstream	Retainer Downstream	Retainer Upstream	Retainer Downstream	Retainer Upstream	Retainer Downstream
80	45	54	79	98	102	136	113	164
100	96	108	145	181	179	237	215	305
150	164	192	289	362	390	520	463	655
200	396	463	651	814	859	1,141	1,107	1,582
250	802	938	1,085	1,356	1,526	2,034	1,898	2,712
300	1,141	1,333	1,266	1,582	2,204	2,938	2,373	3,390
350	1,345	1,582	2,170	2,712	2,802	3,729	3,390	4,859
400	1,582	1,865	3,209	4,012	3,899	5,198	5,142	7,345
450	1,831	2,147	3,887	4,859	5,537	7,345	7,277	10,396
500	2,407	2,825	5,153	6,441	7,458	9,944	9,831	14,012
600	3,729	4,407	8,023	10,057	10,622	14,125	13,899	19,775
750	8,023	9,379	15,481	19,436	20,340	27,120	24,521	35,030
Series 44/45 Fire Safe - Valve Differential Pressure (Bar)								
80	Please Consult Factory							
100								
150								
200								
250								
300								
350								
400								
Series 44/45 Metal Seated - Valve Differential Pressure (Bar)								
80	Please Consult Factory							
100								
150								
200								
250								
300								
350								
400								

DYNAMIC TORQUES

When a media flows through a butterfly valve, static pressure does not act uniformly on the surfaces of the valve disc. Dynamic torque will cause rotary motion when unchecked by the actuator or manual operator possibly resulting in opening or closing of the valve. If the dynamic torque is of a magnitude that is greater than the bearing and packing friction torque and there is no actuator in place to maintain disc position, the opening or closing action could result in injury to operating personnel or an interruption of the process. Sudden closure (slamming) can cause water hammer damage in lines carrying liquid.

In high performance butterfly valves which have the disc offset from the stem and have non-symmetrical disc faces, **dynamic torque acts to close the valve if the valve is installed with the seat retainer downstream, but can act to close or open the valve, depending on the position of the disc, if the seat retainer is upstream.**

Seat Retainer Upstream

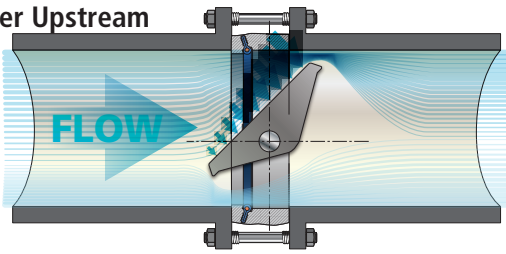

Seat Retainer Downstream

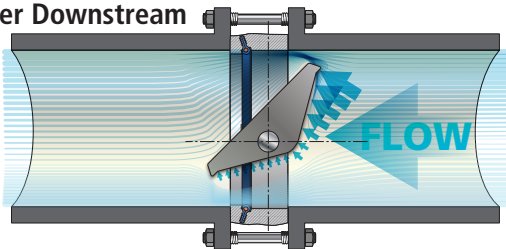

Dynamic torque should be calculated as part of the valve actuator sizing procedure or to determine if hand lever operation is acceptable. In this regard, the total torque of all service conditions must be considered.

The total torque when the disc is in the seat consists of:

1. Seating torque
2. Stem packing torque
3. Eccentricity torque
4. Stem bearing torque

The total torque when the disc is in the seat is published as seating/unseating torque. When the disc is out of the seat, the total torque consists of dynamic torque, stem packing torque, and stem bearing torque.

Total torque changes with the disc position. Maximum total torque can occur at shutoff (disc in the seat), at breakaway (motion initiation), or at any open disc position where the product of valve pressure drop and dynamic torque coefficient peaks in combination with prevailing bearing and packing torque.

Estimating Dynamic Torque

Dynamic torque can be estimated using the following empirical equations:

Liquid Flow:

Imperial . . . $T_d (\text{Lb-in}) = C_t D^3 \Delta p$

Metric. . . . $T_d (\text{N-m}) = .0001 C_t D^3 \Delta p$

Gas Flow:

Imperial . . . $T_d (\text{Lb-in}) = C_t D^3 Y \Delta p$

Metric. . . . $T_d (\text{N-m}) = .0001 C_t D^3 Y \Delta p$

Dynamic Torque - Terminology

C_t - dynamic torque coefficient
(see graphs and tables on page 11 for values of C_t)
Positive value of C_t means that the dynamic torque acts to close the valve and a negative value of C_t to open the valve.

D - nominal valve size (in or mm)

F_k - ratio of specific heat factor (dimensionless)
 $F_k = k/1.40$ or $F_k = 1$ for air

k - ratio of specific heat (dimensionless)

Δp - effective pressure drop across the valve (psi or bar)

p_1 - valve inlet pressure (psia or bar abs.)

T_d - dynamic torque (Lb-in or N-m)

x - $x = \Delta p/p_1$

Y - gas expansion factor (dimensionless)
 $Y = 1 - x / (3 F_k x_t)$

x_t - gas critical pressure ratio (dimensionless)
Values of x_t change with disc position and are identical for seat retainer upstream and downstream.

° Open	x_t	° Open	x_t
10°	0.46	55°	0.31
15°	0.46	60°	0.28
20°	0.46	65°	0.27
25°	0.45	70°	0.25
30°	0.44	75°	0.24
35°	0.42	80°	0.22
40°	0.39	85°	0.21
45°	0.35	90°	0.19
50°	0.33		

DYNAMIC TORQUE COEFFICIENT

Figure 1 - Seat Retainer Downstream

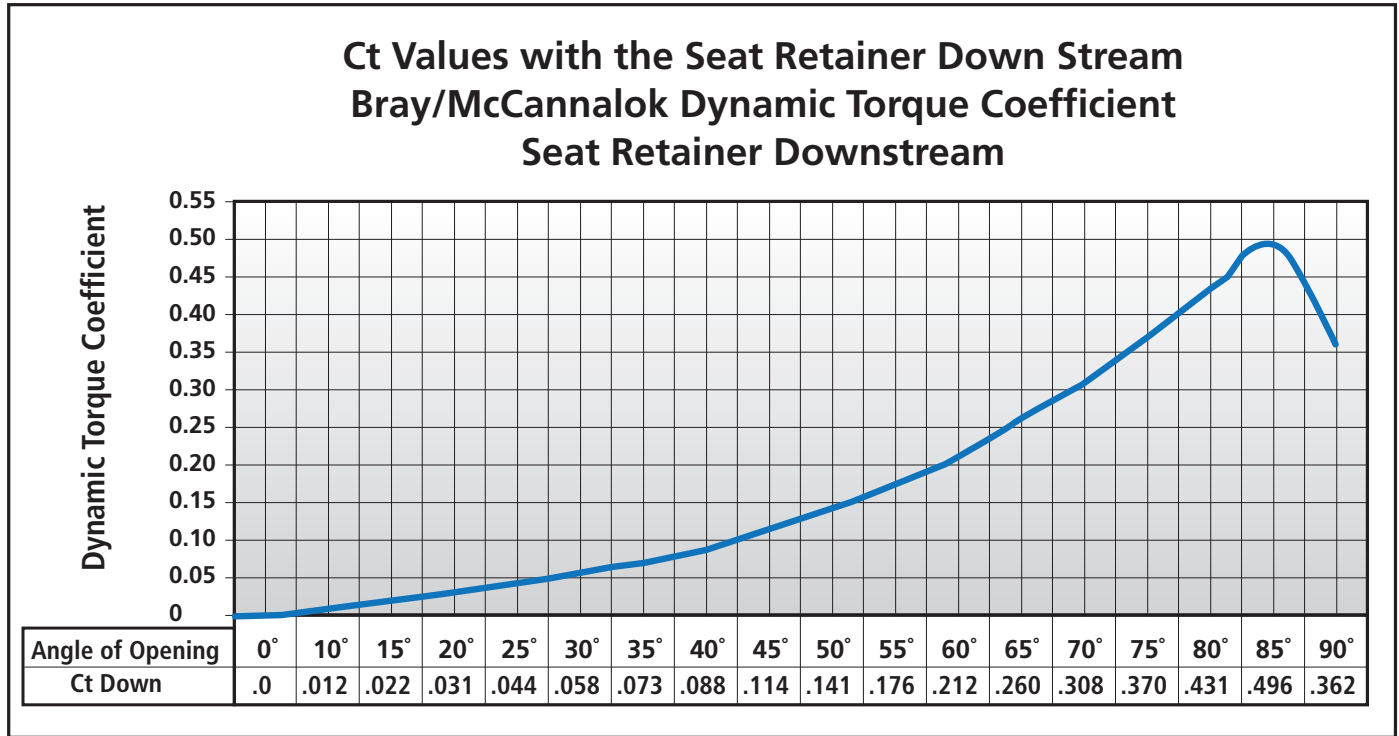
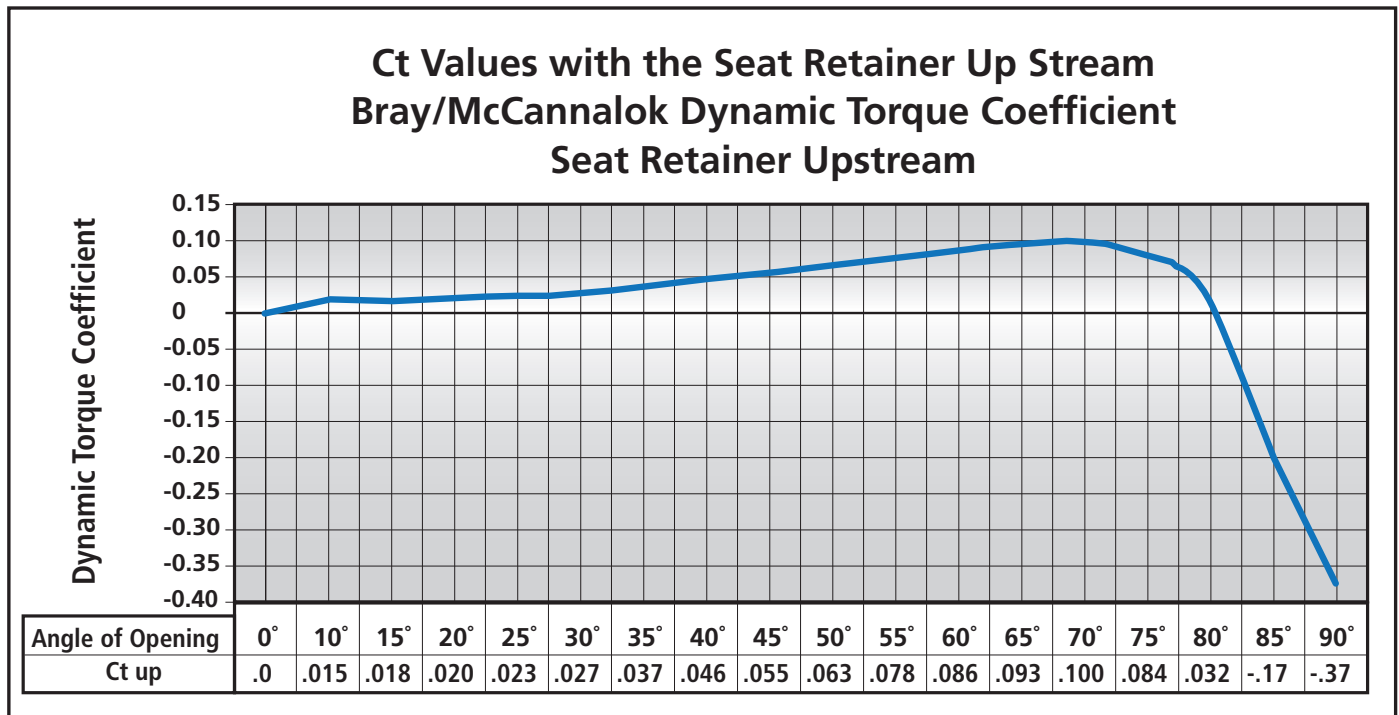

Figure 2 - Seat Retainer Upstream



SUBCHOKED AND CHOKED FLOW

For	Condition	Use	Note
Subchoked Flow	Pipe and Valve Size Equal	<ul style="list-style-type: none"> Nominal Valve Size Valve Pressure Drop Ct from graphs/tables on page 20 and page 21 	
	With Pipe Reducers	<ul style="list-style-type: none"> Nominal Valve Size Ct from graphs/tables on page 20 and page 21 Valve Pressure Drop as if valve were installed in valve-sized pipe with same flow rate 	
Choked Flow	Pipe and Valve Size Equal	<ul style="list-style-type: none"> Nominal Valve Size Ct from graphs/tables on page 20 and page 21 Actual Pressure drop through valve. 	If actual pressure drop at the choked condition is not known, estimate by evaluating the pressure in the piping at the valve outlet needed to sustain the choked flow rate through the piping downstream of the valve; then subtracting it from the valve inlet pressure.
	With Pipe Reducers	<ul style="list-style-type: none"> Nominal Valve Size Ct from graphs/tables on page 20 and page 21 Actual pressure drop through valve/reducer assembly. 	If the pressure drop at the choked condition is not known, estimate the line pressure just downstream of the valve/reducer assembly which is needed to sustain the choked flow rate of the valve/reducer assembly through the downstream piping; then subtract this pressure from the line pressure just ahead of the valve/reducer assembly, to get the actual pressure drop.

For	Condition	Use	Note
Subchoked Flow	Pipe and Valve Size Equal	<ul style="list-style-type: none"> Nominal Valve Size Valve Pressure Drop Ct from graphs/tables on page 20 and page 21 	
	With Pipe Reducers	<ul style="list-style-type: none"> Nominal Valve Size Ct from graphs/tables on page 20 and page 21 Valve Pressure Drop (and expansion factor Y) as if valve were installed in valve-sized pipe with same flow rate. 	In calculating Y, use the line pressure just upstream of the inlet reducer for p1 and xt from the table on page 11.
Choked Flow	Pipe and Valve Size Equal	<ul style="list-style-type: none"> Nominal Valve Size Gas expansion factor Y of 2/3 Ct from graphs/tables on page 20 and page 21 $\Delta p = p_1 F_k x_t$ 	Use xt from the table on page 11.
	With Pipe Reducers	<ul style="list-style-type: none"> Nominal Valve Size Gas expansion factor Y of 2/3 Ct from graphs/tables on page 20 and page 21 $\Delta p = p_1 F_k x_t$ 	Use the line pressure just upstream of the inlet reducer for p1 and xt from the table page 11 in calculating Δp , on page 13.

SUBCHOKED LIQUID FLOW, LINE-SIZE VALVE

Example Calculations	Data
A 24" class 150 McCannalok is to be installed in a 24" line carrying water. It has been determined that the flow is not choked and the following pressure drops through the valve have been calculated:	<ul style="list-style-type: none"> • 75 psi with the valve 20 degrees open • 70 psi with the valve 30 degrees open • 35 psi with the valve 40 degrees open • 3.5 psi with the valve 55 degrees open • 1.1 psi with the valve 60 degrees open • .20 psi with the valve 70 degrees open • .05 psi with the valve 80 degrees open • .03 psi with the valve 90 degrees open
Estimate the maximum dynamic torque in Lb-in for the valve considering installation with the seat retainer upstream.	$T_d = C_t D^3 \Delta p$
Substituting produces following results:	<ul style="list-style-type: none"> • 20 degrees, $T_d = .020 \times 24^3 \times 75 = 20,700$ Lb-in (tends to close the valve) • 30 degrees, $T_d = .027 \times 24^3 \times 70 = 26,100$ Lb-in • 40 degrees, $T_d = .046 \times 24^3 \times 35 = 22,300$ Lb-in • 55 degrees, $T_d = .078 \times 24^3 \times 3.5 = 3,800$ Lb-in • 60 degrees, $T_d = .086 \times 24^3 \times 1.1 = 1,300$ Lb-in • 70 degrees, $T_d = .100 \times 24^3 \times .20 = 300$ Lb-in • 80 degrees, $T_d = .032 \times 24^3 \times .05 = 20$ Lb-in • 90 degrees, $T_d = -.369 \times 24^3 \times .03 = -150$ Lb-in (tends to open the valve)
Thus the peak dynamic torque will occur between 30 and 40 degrees open.	
Verify dynamic torque at 35 degrees:	Approximate pressure drop = $(70+35)/2 = 52.5$ psi. At 35 degrees: $T_d = .037 \times 24^3 \times 52.5 = 27,000$ Lb-in
The peak dynamic torque of approximately 27,000 Lb-in occurs at about 35 degrees open.	
When sizing the valve operator, total torque must be considered. The total torque when the disc is in the seat consists of seating torque, stem packing torque, eccentricity torque and stem bearing torque. The total torque when the disc is in the seat is published as seating/unseating torque (see pages. 1-9. When the disc is out of the seat, total torque consists of dynamic torque, stem packing torque, and stem bearing torque.	

CHOKED GAS FLOW, REDUCED-SIZE VALVE

Example Calculations	Data
20" (DN 500) class 300 McCannalok butterfly valve is installed in a 600 mm (24") line flowing air and the disc is set at 45 degrees. The flow is choked. A pressure gauge tapped into the pipe just above the upstream reducer shows 24.5 bar.	
Estimate the dynamic torque in N-m, given that the seat retainer is installed downstream.	$D = 500$ mm $F_k = 1.0$ $C_t = .114$ $Y = .667$ for choked flow $p_1 = 24.5 + 1.0 = 25.5$ bar absolute, (1 atm. = 1.013 bar, i.e. about 1.0 bar) $x_t \text{ at } 45^\circ = .35$
Calculations:	
$\Delta p = p_1 F_k x_t$	$T_d = .0001 C_t D^3 Y \Delta p$
$\Delta p = 25.5 \times 1.0 \times .35 = 8.9$ bar	$T_d = .0001 \times .114 \times 500^3 \times .667 \times 8.9 = 8,500$ N-m
Thus the dynamic torque at 45° open is about 8,500 N-m, and acts to close the valve.	

MAXIMUM ALLOWABLE STEM TORQUES (Lb-in)*

Standard, Fire Safe and Metal Seated Valves

Valve Size inches	ASME 150	ASME 300	ASME 600
	Series S40/41/4A	Series S42/43/4B	Series 44/45
2	1,347	Please Consult Factory	
2.5	1,968	1,968	Please Consult Factory
3	1,968	1,968	3,368
4	1,968	1,968	5,630
5	3,368	3,368	Please Consult Factory
6	3,368	5,630	9,945
8	5,544	10,292	27,818
10	10,251	18,511	64,635
12	14,454	27,818	81,314
14	27,818	64,635	136,042
16	64,635	136,042	221,381
18	81,314	136,042	375,962
20	136,042	149,811	550,204
24	149,811	375,962	802,018
26	149,811	Please Consult Factory	
28	221,381	Please Consult Factory	
30	375,962	771,674	Please Consult Factory
32	375,962	Please Consult Factory	
34	375,962	Please Consult Factory	
36	431,471	802,018	
40	771,674	1,484,117	
42	771,674	1,484,117	
48	802,018	1,622,749	
54	1,484,117	2,364,969	
60	1,622,749		

* Based on stem Material Code 54P (17-4 PH stainless steel, ASTM A564 Type 630 H1150D)

MAXIMUM ALLOWABLE STEM TORQUES (N-m)*

Standard, Fire Safe and Metal Seated Valves

Valve Size mm	ASME 150	ASME 300	ASME 600
	Series S40/41/4A	Series S42/43/4B	Series 44/45
50	152	Please Consult Factory	
65	222	222	Please Consult Factory
80	222	222	380
100	222	222	636
125	380	380	Please Consult Factory
150	380	636	1,124
200	626	1,163	3,143
250	1,158	2,091	7,303
300	1,633	3,143	9,187
350	3,143	7,303	15,371
400	7,303	15,371	25,013
450	9,187	15,371	42,478
500	15,371	16,926	62,165
600	16,926	42,478	90,616
650	16,926	Please Consult Factory	
700	25,013	Please Consult Factory	
750	42,478	87,187	Please Consult Factory
800	42,478	Please Consult Factory	
850	42,478	Please Consult Factory	
900	48,750	90,616	
1000	87,187	167,683	
1050	87,187	167,683	
1200	90,616	183,346	
1350	167,683	267,206	
1500	183,346		

* Based on stem Material Code 54P (17-4 PH stainless steel, ASTM A564 Type 630 H1150D)

VALVE SIZING COEFFICIENTS (Cv)

- Cv stands for Valve Sizing Coefficient.
- Cv varies with the valve size, angle of opening and the manufacturer's valve style.
- Cv is defined as the volume of water in USGPM that will flow through a given restriction or valve opening with a pressure drop of one (1) psi at room temperature.

ASME 150 Series 40/41/4A - Valve Sizing Coefficient (Cv)									
Valve Size Inches	Disc Position (Degrees)								
	90°	80°	70°	60°	50°	40°	30°	20°	10°
2.5	160	136	100	78	50	30	16	8	3
3	185	178	155	123	87	56	32	14	5
4	375	365	315	250	175	115	63	31	10
5	790	675	500	360	238	146	78	41	16
6	1,350	1,070	750	510	330	218	140	81	35
8	2,800	2,230	1,590	1,060	685	456	280	165	65
10	4,300	3,450	2,430	1,630	1,050	700	450	250	100
12	6,650	5,330	3,750	2,530	1,630	1,080	700	390	155
14	7,650	6,100	4,300	2,900	1,890	1,250	810	450	175
16	9,800	7,860	5,510	3,700	2,420	1,530	1,020	580	230
18	10,500	9,100	6,960	5,100	3,520	2,220	1,180	500	170
20	13,500	11,700	8,800	6,500	4,500	2,820	1,530	640	200
24	20,000	17,100	12,800	9,570	6,640	3,880	2,200	920	240
26	20,000	17,100	12,800	9,570	6,640	3,880	2,200	920	240
28	28,000	23,900	18,200	13,500	9,300	5,700	3,100	1,300	290
30	32,000	27,300	20,900	15,500	10,700	6,700	3,600	1,510	320
32	34,000	29,100	22,300	16,500	11,400	7,150	3,850	1,610	340
34	34,000	29,100	22,300	16,500	11,400	7,150	3,850	1,610	340
36	48,500	41,100	31,700	23,200	16,400	10,200	5,430	2,260	480
40	62,000	55,200	44,000	33,300	23,800	15,200	8,600	3,520	670
42	65,000	58,000	46,100	35,000	25,000	16,000	9,000	3,700	700
48	91,000	80,900	63,700	43,600	29,100	20,000	11,000	4,600	920
54	125,000	111,000	87,500	60,000	40,000	27,500	15,000	6,000	1,200
60	160,000	140,000	105,000	75,000	50,000	31,000	17,000	7,000	1,400

ASME 300 Series 42/43/4B - Valve Sizing Coefficient (Cv)									
Valve Size Inches	Disc Position (Degrees)								
	90°	80°	70°	60°	50°	40°	30°	20°	10°
2.5	160	136	100	78	50	30	16	8	3
3	185	178	155	123	87	56	32	14	5
4	375	365	315	250	175	115	63	31	10
5	790	675	500	360	238	146	78	41	16
6	1,000	875	710	530	370	240	138	79	26
8	2,000	1,720	1,360	950	630	405	240	121	47
10	2,650	2,250	1,740	1,200	780	510	295	150	61
12	4,000	3,400	2,500	1,690	1,100	710	430	220	92
14	4,100	3,500	2,600	1,770	1,200	830	490	240	100
16	7,800	6,540	4,550	2,970	1,840	1,160	730	420	180
18	9,500	8,000	6,170	4,530	3,110	1,970	1,080	440	94
20	11,000	9,570	7,300	5,400	3,720	2,330	1,250	530	110
24	18,000	15,100	11,400	8,570	5,920	3,700	2,000	830	180
30	29,000	24,400	18,900	13,700	8,500	6,000	3,230	1,330	290
36	45,000	38,100	29,200	21,000	14,800	9,100	4,660	1,730	380
42	60,000	54,000	42,000	30,000	19,000	13,000	7,500	2,600	450
48	83,000	74,000	58,000	41,000	26,000	17,000	10,000	4,400	800
54	Please Consult Factory								

ASME 600 Series 44/45 - Valve Sizing Coefficient (Cv)									
Valve Size Inches	Disc Position (Degrees)								
	90°	80°	70°	60°	50°	40°	30°	20°	10°
3	165	158	135	103	67	46	12	8	3
4	300	270	210	150	95	70	45	30	5
6	800	765	600	425	270	200	130	70	15
8	1,500	1,350	1,050	750	480	345	209	78	20
10	2,200	1,970	1,540	1,100	700	500	300	140	40
12	3,100	2,790	2,170	1,550	1,000	680	400	190	55
14	3,900	3,300	2,400	1,570	1,100	730	420	200	70
16	5,000	4,200	2,900	1,900	1,200	800	500	250	95
18	6,000	5,000	3,900	2,800	1,900	1,200	660	290	130
20	8,000	6,900	5,300	3,900	2,700	1,700	950	400	143
24	11,000	9,300	7,000	5,200	3,600	2,250	1,200	500	180
30	15,000	13,000	10,000	8,400	5,100	2,800	1,650	600	200

VALVE SIZING COEFFICIENTS (Kv)

- Kv stands for Valve Sizing Coefficient.
- Kv varies with the valve size, angle of opening and the manufacturer's valve style.
- Kv is defined as the volume of water in Cubic Meters/Hour (m3/hr) that will flow through a given restriction or valve opening with a pressure drop of one (1) bar at room temperature.

Valve Size mm	ASME 150 Series 40/41/4A - Valve Sizing Coefficient (Kv)								
	Disc Position (Degrees)								
	90°	80°	70°	60°	50°	40°	30°	20°	10°
65	136	116	85	67	43	26	14	7	3
80	158	152	132	105	74	48	27	12	4
100	320	311	269	213	149	98	54	26	9
125	674	576	427	307	203	125	67	35	14
150	1,152	913	640	435	281	186	119	69	30
200	2,388	1,902	1,356	904	584	389	239	141	55
250	3,668	2,943	2,073	1,390	896	597	384	213	85
300	5,672	4,546	3,199	2,158	1,390	921	597	333	132
350	6,525	5,203	3,668	2,474	1,612	1,066	691	384	149
400	8,359	6,705	4,700	3,156	2,064	1,305	870	495	196
450	8,957	7,762	5,937	4,350	3,003	1,894	1,007	427	145
500	11,516	9,980	7,506	5,545	3,839	2,405	1,305	546	171
600	17,060	14,586	10,918	8,163	5,664	3,310	1,877	785	205
650	17,060	14,586	10,918	8,163	5,664	3,310	1,877	785	205
700	23,884	20,387	15,525	11,516	7,933	4,862	2,644	1,109	247
750	27,296	23,287	17,828	13,222	9,127	5,715	3,071	1,288	273
800	29,002	24,822	19,022	14,075	9,724	6,099	3,284	1,373	290
850	29,002	24,822	19,022	14,075	9,724	6,099	3,284	1,373	290
900	41,371	35,058	27,040	19,790	13,989	8,701	4,632	1,928	409
1,000	52,886	47,086	37,532	28,405	20,301	12,966	7,336	3,003	572
1,050	55,445	49,474	39,323	29,855	21,325	13,648	7,677	3,156	597
1,200	77,623	69,008	54,336	37,191	24,822	17,060	9,383	3,924	785
1,350	106,625	94,683	74,638	51,180	34,120	23,458	12,795	5,118	1,024
1,500	136,480	119,420	89,565	63,975	42,650	26,443	14,501	5,971	1,194

ASME 300 Series 42/43/4B - Valve Sizing Coefficient (Kv)									
Valve Size mm	Disc Position (Degrees)								
	90°	80°	70°	60°	50°	40°	30°	20°	10°
65	136	116	85	67	43	26	14	7	3
80	158	152	132	105	74	48	27	12	4
100	320	311	269	213	149	98	54	26	9
125	674	576	427	307	203	125	67	35	14
150	853	746	606	452	316	205	118	67	22
200	1,706	1,467	1,160	810	537	345	205	103	40
250	2,260	1,919	1,484	1,024	665	435	252	128	52
300	3,412	2,900	2,133	1,442	938	606	367	188	78
350	3,497	2,986	2,218	1,510	1,024	708	418	205	85
400	6,653	5,579	3,881	2,533	1,570	989	623	358	154
450	8,104	6,824	5,263	3,864	2,653	1,680	921	375	80
500	9,383	8,163	6,227	4,606	3,173	1,987	1,066	452	94
600	15,354	12,880	9,724	7,310	5,050	3,156	1,706	708	154
750	24,737	20,813	16,122	11,686	7,251	5,118	2,755	1134	247
900	38,385	32,499	24,908	17,913	12,624	7,762	3,975	1476	324
1,050	51,180	46,062	35,826	25,590	16,207	11,089	6,398	2218	384
1,200	70,799	63,122	49,474	34,973	22,178	14,501	8,530	3753	682
1,350	Please Consult Factory								

ASME 600 Series 44/45 - Valve Sizing Coefficient (Kv)									
Valve Size mm	Disc Position (Degrees)								
	90°	80°	70°	60°	50°	40°	30°	20°	10°
80	141	135	115	88	57	39	10	7	3
100	256	230	179	128	81	60	38	26	4
150	735	662	519	368	234	173	112	61	13
200	1,280	1,152	896	640	409	294	178	67	17
250	1,877	1,680	1,314	938	597	427	256	119	34
300	2,644	2,380	1,851	1,322	853	580	341	162	47
350	3,327	2,815	2,047	1,339	938	623	358	171	60
400	4,265	3,583	2,474	1,621	1,024	682	427	213	81
450	5,118	4,265	3,327	2,388	1,621	1,024	563	247	111
500	6,824	5,886	4,521	3,327	2,303	1,450	810	341	122
600	9,383	7,933	5,971	4,436	3,071	1,919	1,024	427	154
750	12,795	11,089	8,530	7,165	4,350	2,388	1,407	512	171

PRESSURE-TEMPERATURE CHARTS - STANDARD MCCANNALOK VALVES

Figure 3

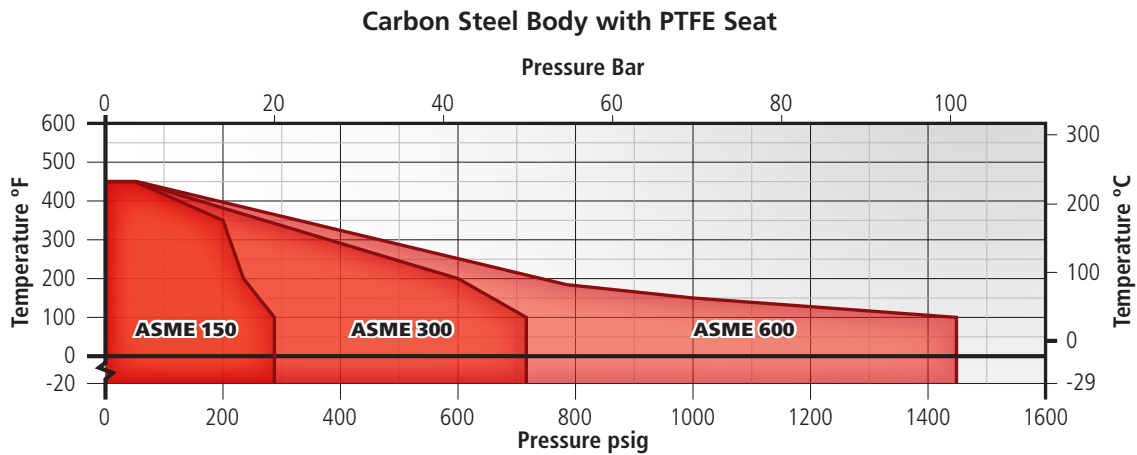
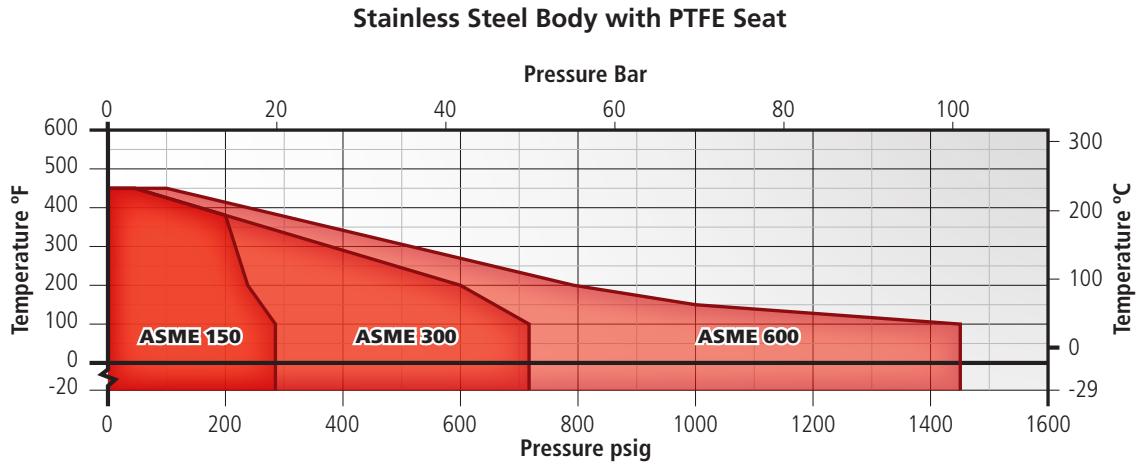

Note: Valves in all pressure classes are rated to a maximum pressure rating of 150 psig (10.3 bar) in steam service applications.

PRESSURE TEMPERATURE CHARTS - STANDARD MCCANNALOK VALVES

Figure 4

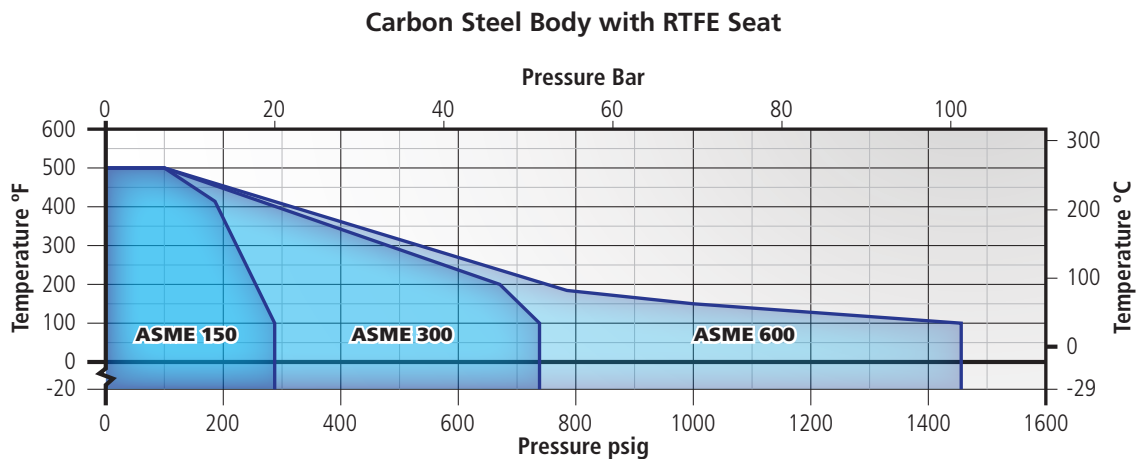
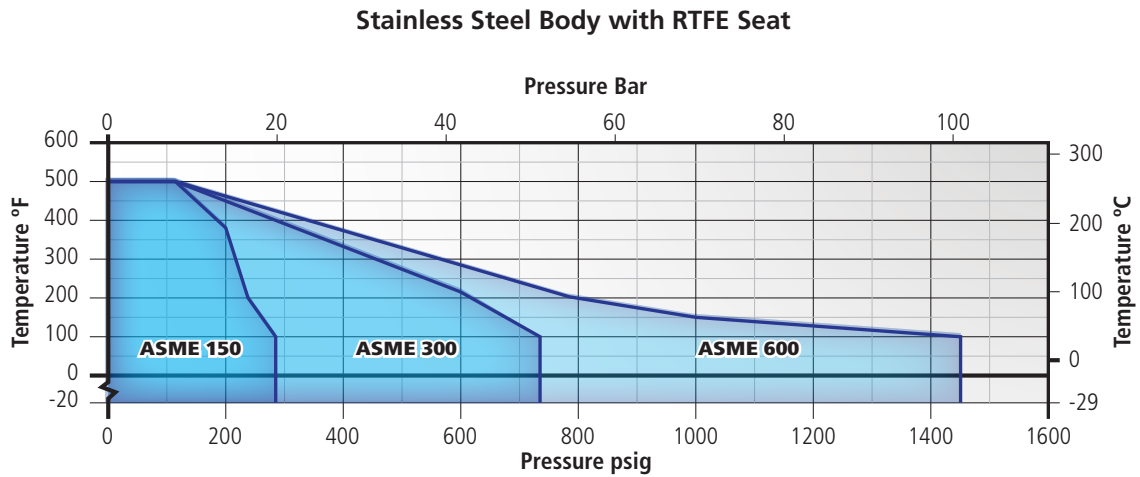

Note: Valves in all pressure classes are rated to a maximum pressure rating of 150 psig (10.3 bar) in steam service applications.

PRESSURE-TEMPERATURE CHARTS - FIRESAFE MCCANNALOK VALVES

Figure 5

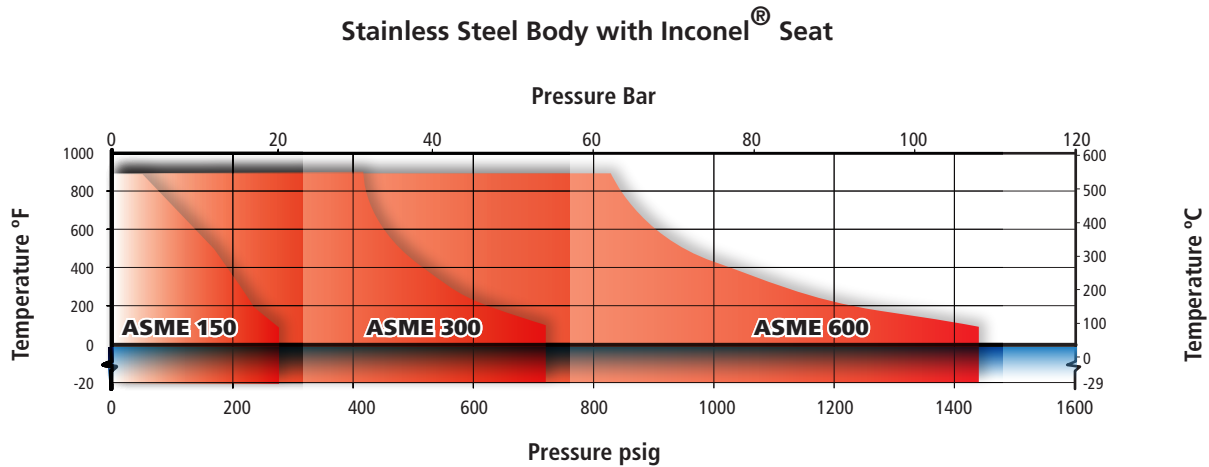
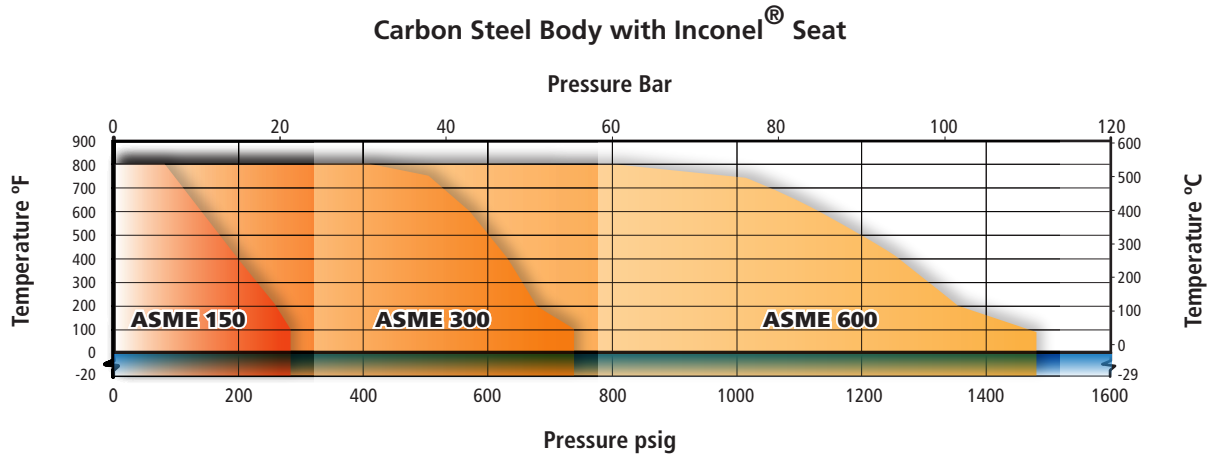

PRESSURE TEMPERATURE CHARTS - CRYOGENIC MCCANNALOK VALVES

Figure 6

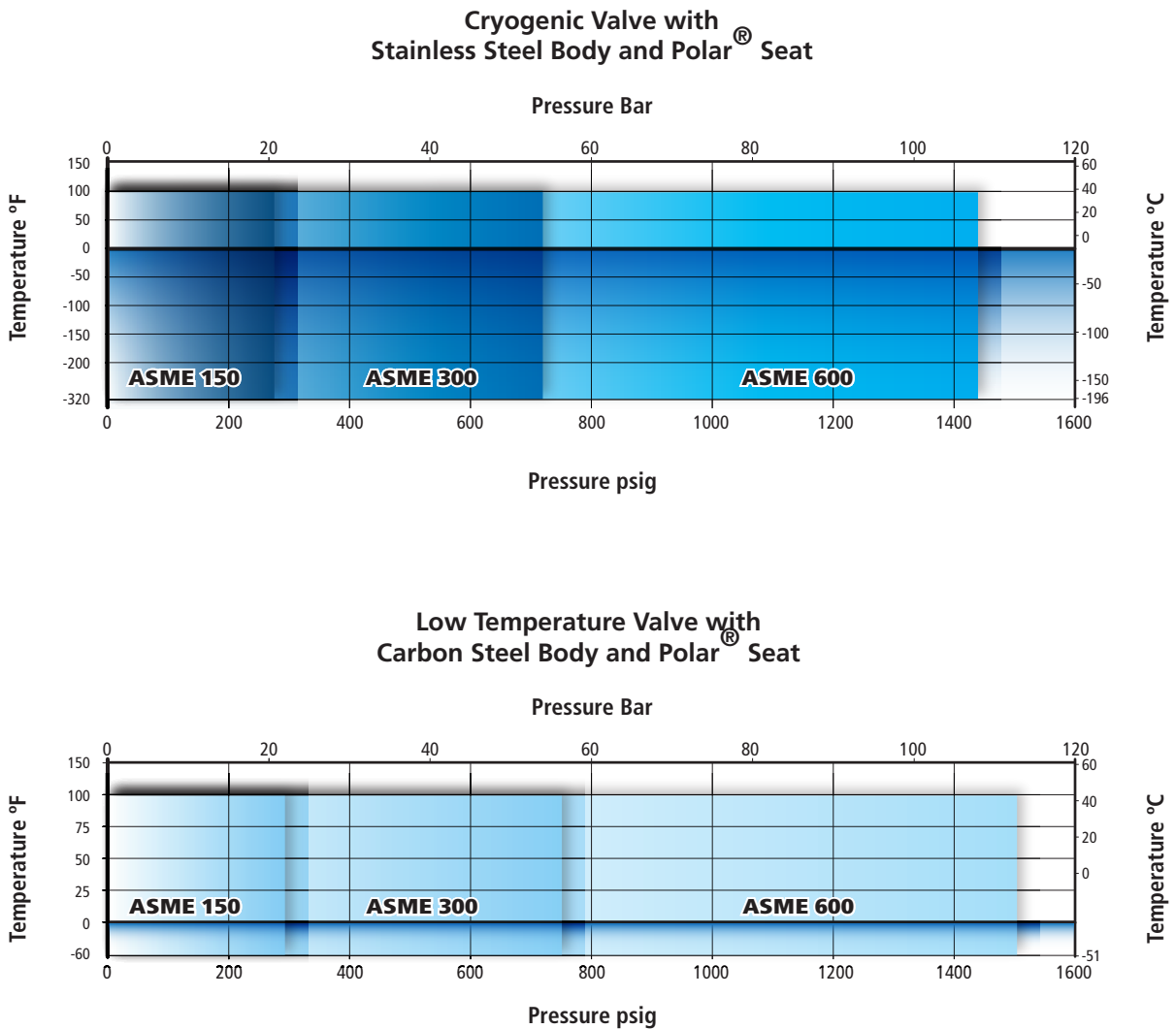

EXAMPLES OF TYPICAL FLANGE TO VALVE BOLTING*

Lug Style Bolting

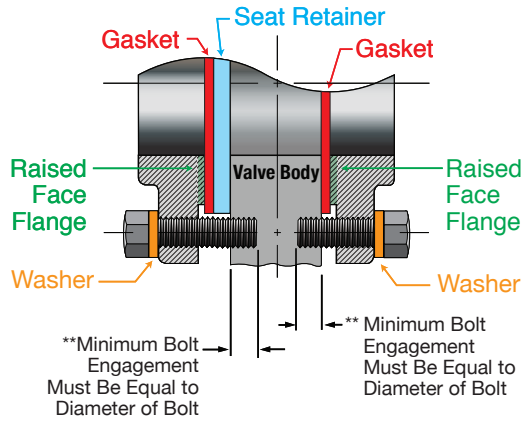

Wafer Style Bolting

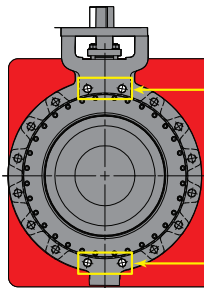
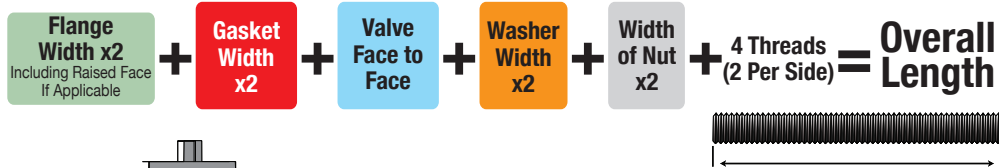
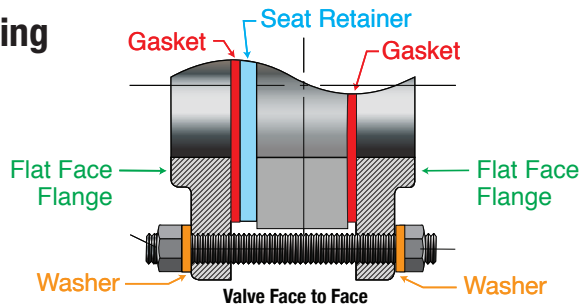

Note: Please refer to Appropriate Bray Dimensional Drawings for specific valve drilling information.

Applies to Wafer and Lug Valves as follows:
 ASME Class 150 26" Valves and larger
 ASME Class 300 14" Valves and larger
 ASME Class 600 10" Valves and larger

Please refer to ASME B-16.5 or B-16.47 for Flange and Bolt Dimension Information

* Double flange style bolting not shown.

** Lug Threads may be tapped from both sides and therefore tap may not be continuous.

All statements, technical information, and recommendations in this bulletin are for general use only. Consult Bray representatives or factory for the specific requirements and material selection for your intended application. The right to change or modify product design or product without prior notice is reserved. Patents issued and applied for worldwide.

Bray® is a registered trademark of
Bray International, Inc.

© 2015 Bray International, Inc. All rights reserved.

TM_1023_540_06_01_2015



Bray Controls

Division of Bray International, Inc.
13333 Westland East Blvd.

Houston, Texas 77041

Tel: 281.894.5454 • www.bray.com