

Flow-Tek[®]

A Subsidiary of BRAY INTERNATIONAL, Inc.

INSTALLATION - MAINTENANCE MANUAL

Severe-Tek[™] Series M1
Severe Service Ball Valve

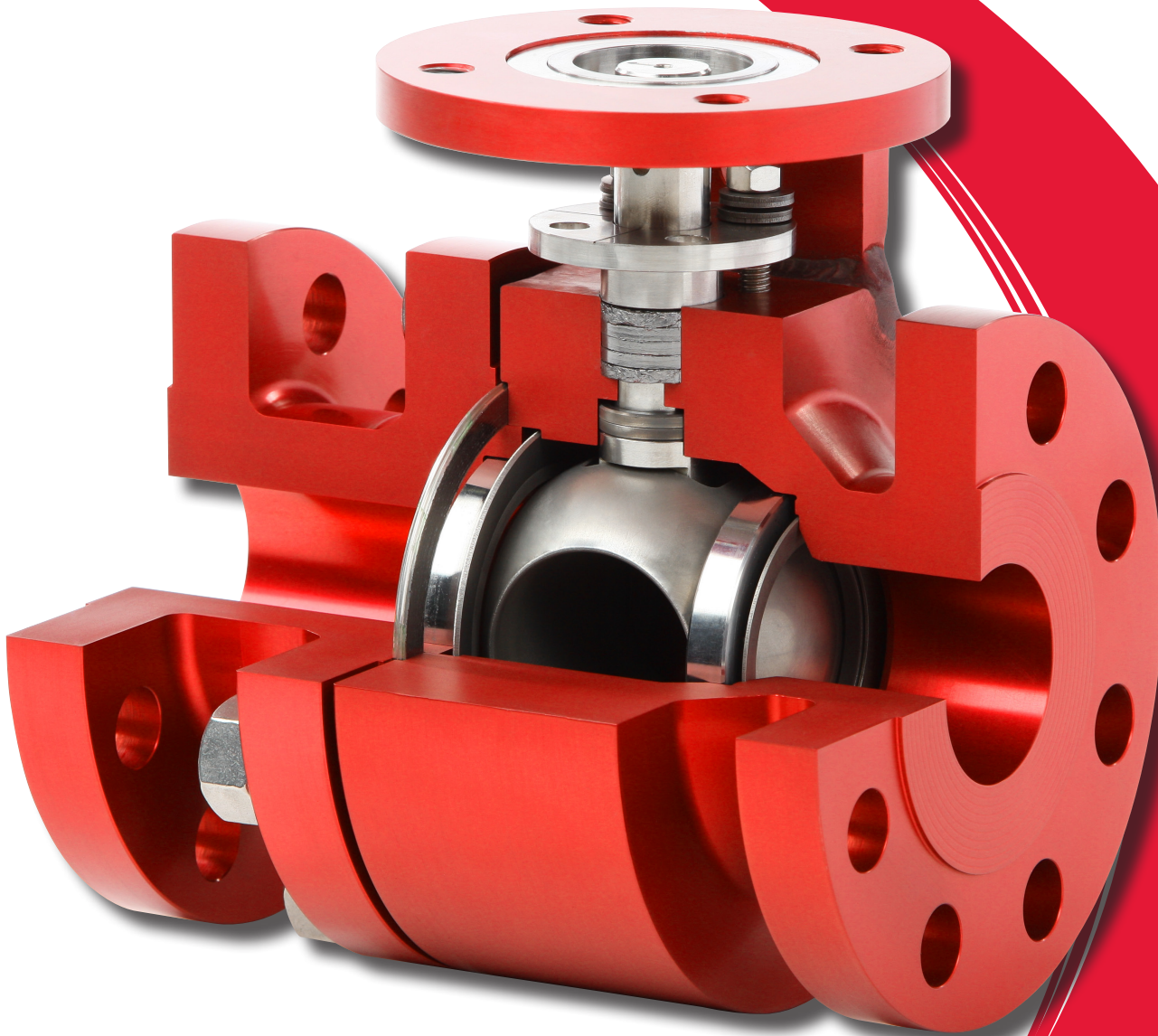

Table of Contents

| | |
|---|----|
| Safety Instructions - Definition of Terms | 3 |
| 1. Bill of Materials | 4 |
| 2. Design | 5 |
| 3. Handling and Lifting | 5 |
| 4. General Warnings and Cautions | 5 |
| 5. Installation. | 6 |
| Removing Valve from Service | 7 |
| 6. Operation | 8 |
| Valve in Open Position | 8 |
| Valve in Closed Position | 8 |
| Visual Indicators. | 8 |
| 7. Maintenance | 9 |
| 8. Valve Disassembly | 10 |
| 9. Transport and Storage | 10 |
| Short Term Storage | 10 |
| Long Term Storage | 10 |
| 10. Service Contact | 10 |

SAFETY INSTRUCTIONS - DEFINITION OF TERMS

READ AND FOLLOW THESE INSTRUCTIONS:



WARNING

indicates a potentially hazardous situation which, if not avoided, could result in death or serious injury.



CAUTION

indicates a potentially hazardous situation which, if not avoided, may result in minor or moderate injury.

NOTICE

used without the safety alert symbol indicates a potential situation which, if not avoided, may result in an undesirable result or state, including property damage.

1. BILL OF MATERIALS

| ITEM # | Component | ITEM # | Component |
|--------|-------------------------|--------|---------------------------|
| 1 | Body | 11 | Mounting Flange (Bracket) |
| 2 | Ball | 12 | Outer Stem Bushing |
| 3 | Primary Seat Ring | 13 | Stem Bushing Insert |
| 4 | Reverse Seat Ring | 14 | Packing Studs |
| 5 | Seat Spring | 15 | Belleville Washers |
| 6 | Locking Ring | 16 | Packing Nuts |
| 7 | Stem | 17 | Closure |
| 8 | Inner Stem Bushings | 18 | Body Studs |
| 9 | Gland Flange (Follower) | 19 | Body Hex Nuts |
| 10 | Packing Set | 20 | Body Gasket |

| | | | |
|-------------------|--------|-----------|-----------|
| Severe-Tek | MODEL: | SIZE: | B16.34: |
| | BODY: | BALL: | SEAT: |
| | STEM: | B/S CTG.: | MAX T: °F |
| | MAX P: | psi@100F | bar@38C |
| S/N: | P/N: | | |

| NAMEPLATE INFO | STAMP |
|----------------|--------------------|
| MODEL: | Valve Series Model |
| SIZE: | Nominal End Size |
| B16.34 | Pressure Class |
| BODY: | Body Material |
| BALL: | Ball Material |
| SEAT: | Seat Material |

| NAMEPLATE INFO | STAMP |
|----------------|------------------------|
| STEM: | Stem Material |
| B/S CTG: | Ball/Seat Coating Code |
| MAX P: | Maximum Pressure |
| MAX T: | Maximum Temperature |
| S/N: | Valve Serial Number |
| P/N: | Valve Part Number |

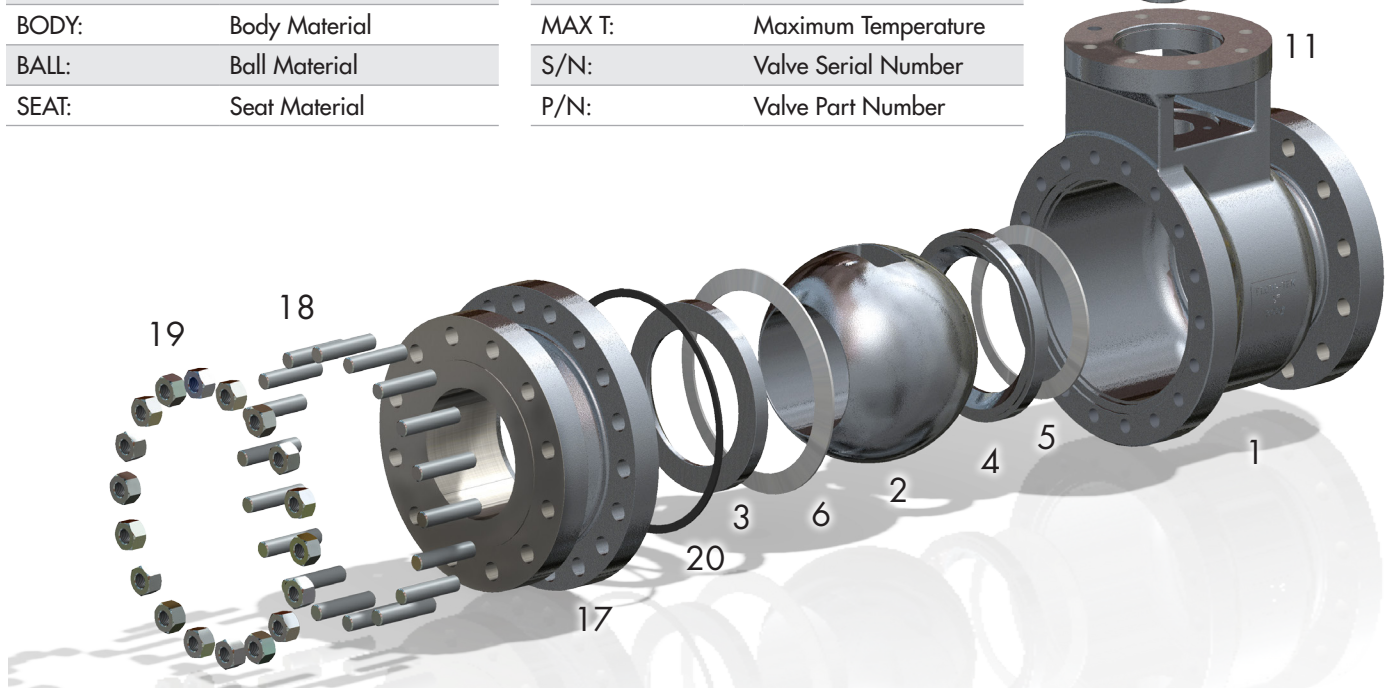

2. DESIGN

Our Severe-Tek™ Series M1 is designed as a “free floating” ball valve with metal seats. It is important to install the valve in the pipe considering its intended purpose to achieve best performance. If there are any questions regarding the best orientation of the valve, contact Severe-Tek™.

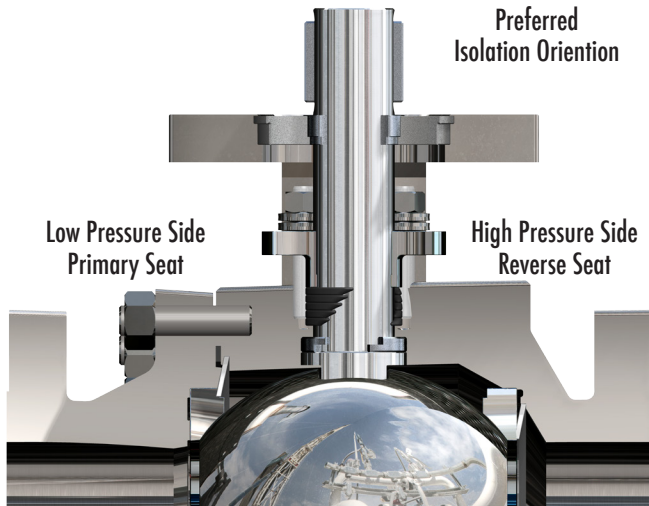

3. HANDLING AND LIFTING

The valve should be lifted in such a way that the body supports the load. Use the lifting eyes provided on large valves

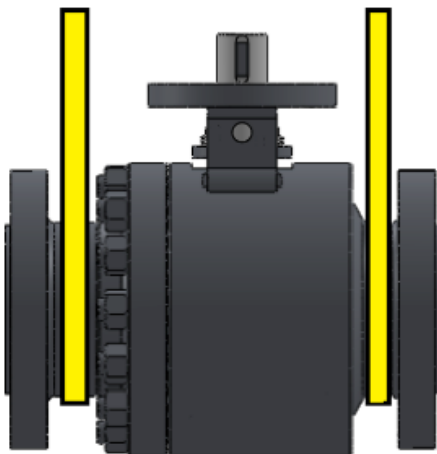

The end protector covers should be kept in place during handling. Remove only during final installation of the valve.



CAUTION

Unless lifting eyes are provided, the end connection necks are suitable places to attach lifting slings/straps. Never use hand wheels or other protruding parts of the gearbox or actuator not designated for this purpose.



CAUTION

During handling, protect the end connection faces and fittings against damage from the lifting devices. Failure to cover faces and fittings could cause damage to the valve.

4. GENERAL WARNINGS AND CAUTIONS

1. During shipment, storage, and in operation, the valve should be fully open or fully closed.
2. Ensure that the line is depressurized and drains are open/monitored during installation
3. Before working on valve make sure that service media has been flushed and line is safe. Ensure that all applicable MSDS sheets are available. Follow all safety related procedures.
4. While line is under pressure, DO NOT remove packing gland or any other valve parts.
5. Ensure that the valve is being used for its intended purpose, i.e. suitable pressure/temp rating, to prevent valve failure.



WARNING

Before installing this equipment, confirm that it is suitable for the intended service. The identification tags describe the maximum allowable service conditions for this product. Be sure that the installation is protected by appropriate pressure control and safety devices to insure that acceptable limits are not exceeded.

5. INSTALLATION



WARNING

Reasonable precaution should be taken before beginning any work on the valve.

Protective clothing, as required by specific line fluid, should be worn.

Depressurize the line and close the valve before removing the actuation device from the valve.

Do not pressurize the line without an actuation device properly installed and working on the valve.

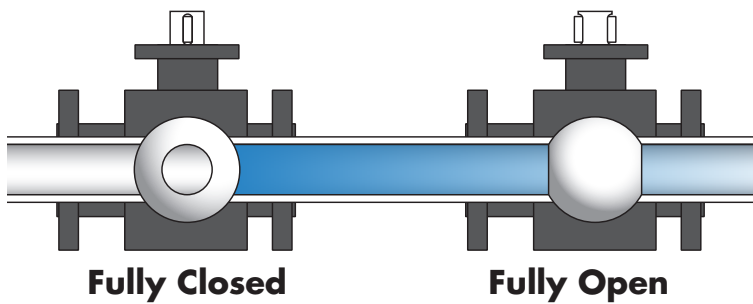

The valve may be installed in any position, vertically or horizontally, on the pipeline. Before installing the valve, the valve should be placed in the full open position.



CAUTION

All welding/grinding debris must be thoroughly flushed from all associated piping before valve is installed or actuated.

Due to potential for packing consolidation, verify proper packing torque adjustment prior to placing valve in service.

Larger valves and actuators may need external support to prevent excess piping loads from effecting valve operation.

1. Verify operating position. Refer to Section 6 – Operation for more information.

2. Identify the sealing direction of the pipeline/valve. High pressure end is marked on valve end as "HP END". The HP END side is the preferred higher pressure side when the valve is in the closed position.

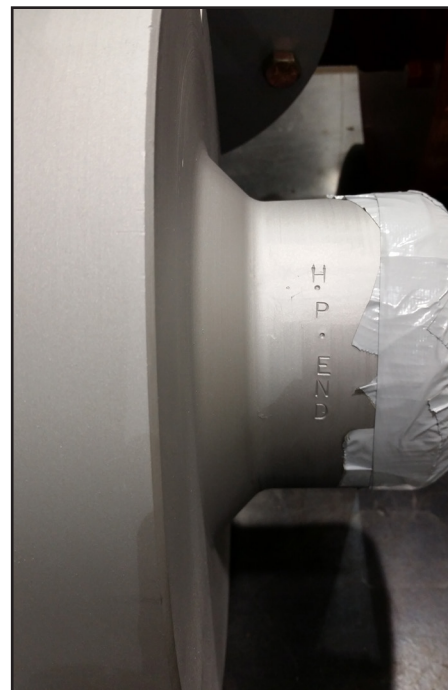

- Position and install the "HP END" side towards the pipeline side with the higher pressure.

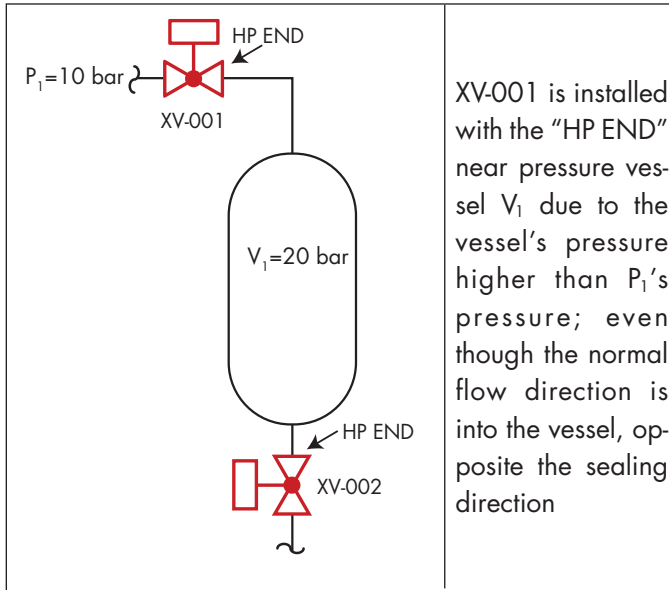

- Position valve in piping. Verify that the valve and actuator or handle orientation is correct.

Note: Support or lift as required, using lifting lugs or nylon straps around the valve body. Do not lift or support by the actuator alone. Refer to Section 3 – Handling and Lifting for more information.

- Install valve in line by bolting, welding or clamping.
- After installation, the pipeline and valve must be flushed clean of dirt, burrs, and welding residues or the seats and ball surface will be damaged.
- After installation, open and close several times to ensure smooth operation.

Removing Valve from Service

Before the valve is removed from service it should be placed in the open position to prevent internal damage to valve components.

6. OPERATION

Operation of the valve is done by turning the valve stem 90° to 95°. Clockwise (CW) to close, Counterclockwise (CCW) to open. The operation requires greater angular movement than 90° to account for clearances in the ball and stem.

Valve in Open Position

The valve handle, stem keyways or actuator indicator is parallel with the pipeline.

Valves with actuators should be checked for alignment. Consult actuator manufacturer's instructions for proper setting of stops.

Valve in Closed Position

The valve handle, stem keyways or actuator indicator is perpendicular to the pipeline.

Note: Valve keyways are in-line with valve bore. If keyway are perpendicular to pipeline, then valve is in the closed position.

If keyway are parallel to pipeline, then valve is in the open position.

If the valve is in the "closed" position, the scribe line on the stem should be aligned with the scribe line on the gland and perpendicular to the valve bore.

Visual Indicators

The scribe line is used to set operator open/close stops if the operator cannot be removed from valve



WARNING

Avoid 180° rotation of the ball and/or stem as this could cause premature wear to the ball/seat lapping surface thus reducing effective sealing / isolation which may lead to void of warranty.



WARNING

When stroking the valve, make sure that it is stroked from fully open to fully closed or vice versa to wipe away any accumulation of debris on the ball and seat sealing surfaces. This ensures optimal performance and long valve life. Failure to fully stroke the valve may lead to void of warranty.

7. MAINTENANCE

Check the bolting at these locations periodically. If bolting torque is lower than the specified values, re-torque bolting as necessary.

1. Gland Flange (or Stem Packing)
2. Valve Operator Mounting

Refer to Test Certificate for proper bolting torque values or call your local distributor or factory

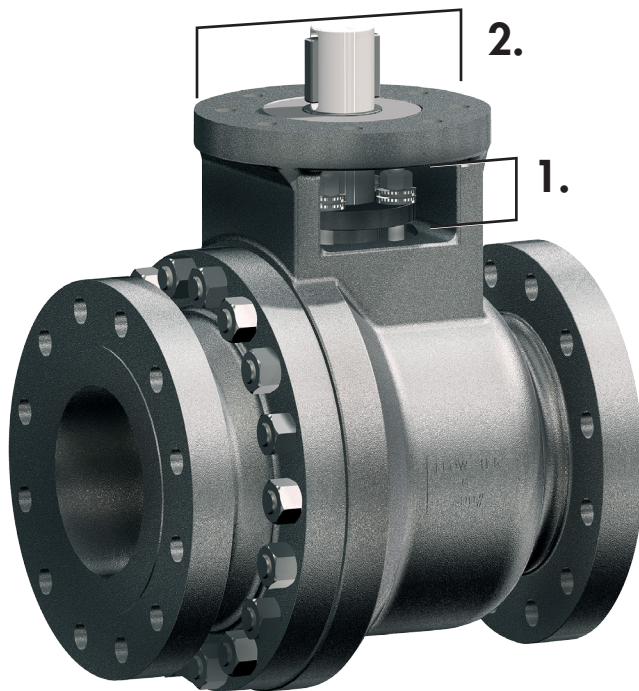

CAUTION





Check packing gland nuts periodically, and re-torque if necessary.

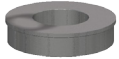

NOTICE

Open / Close the valve intermittently (at least once a year). Valves should always be fully opened or fully closed to wipe away any accumulation on the sealing surfaces.

Packing Procedure:

1. Mark any matching components with a marker or tape prior to disassembly, for ease of reassembly.
2. Remove the operator, bracket (or mounting flange adaptor), and stem adaptor if present.  13
3. Remove stem keys.  12
4. Remove bearing retainer (12) and stem bearing (13).  16
15
5. Loosen and remove nuts (16) holding gland flange (9) in place.  14
9
6. Remove Belleville washers (15), studs (14), and gland retainer / flange (9).  10
7. Using a small pick or scribe, carefully remove stem packing set (10) which includes anti-extrusion rings from the packing box. Make sure that all of the packing is removed.  7
8. Clean packing box before installing the new packing set.



CAUTION

Do not scratch the stem or the packing bore in the body. Scratches could cause a leak.

Before installing the new packing, make sure the packing box is clean. Use of an air hose to clean debris from packing box is permitted.

9. Install the new packing set (10); install the rings one at a time. Packing set should have an anti-extrusion ring on each end. Use the gland flange (9) as a packing tool to stuff each packing ring all the way down against the previous ring.

10. Verify that the scribe line on the stem (7) is facing the body/closure joint.
11. Install the gland flange (9) over the stem (7) so that one of its scribe lines is facing the body closure joint. If necessary rotate the stem so that the two scribe lines are aligned.



CAUTION

A gland flange must be pulled down evenly to prevent cocking or side loading, as this could cause damage to the packing and prevent the valve from operating properly.

Make sure that the gland flange remains perpendicular to the stem, and the gap around the stem remains concentric during tightening process.

Do not over-tighten nuts. Torque all nuts evenly per specified packing torque.

12. Apply lubricant to stud threads (14) and bottom face of hex nuts (16).
13. Insert studs (14), into threaded holes. Insert the Belleville springs/washers (15) onto each stud. Belleville washers shall be stacked in alternating direction (series stack). Install nuts (16) onto each stud and torque to specified value. Be sure to torque in a cross pattern to avoid uneven loading. **Packing assembly torques are given on the Valve Test Form.**
14. Install bearing retainer (12) and stem bearing (13) into the mounting flange (11). If necessary, tap gently into place using a soft hammer. Valve is ready for installing the actuator, or handle.
15. Insert keys into the stem (7). Ensure key length provides and maintains full engagement.



8. VALVE DISASSEMBLY

Your Severe-Tek™ valves have been carefully fitted and assembled for optimum performance and long life. It is not recommended that the valves be disassembled without factory supervision or specific instructions provided by the Severe-Tek™ Service Department.

9. TRANSPORT AND STORAGE

Valves will be shipped in a manner to minimize damage during transit. Upon arrival at the site, valves general condition shall be inspected right away for any shipping damage. Any damage shall be reported to Flow-Tek.

Short Term Storage

1. Short term storage is defined as storage of products and equipment to be used in the construction of a project for periods of one to three months.
2. Ball valves should remain in the original shipping containers. End protectors should remain on the valve ends to prevent the entrance of dirt.
3. Valves should be stored in the open position to protect the ball and seat.
4. Storage of ball valves can be in an open uncovered area provided provisions are made for inclement weather such as covering with tarps or sheeting. Valves with actuators shall be stored under cover until ready for installation.

Long Term Storage

1. Long term storage is storage of products and or equipment for periods of three months or more.
2. Valves should be stored in the open position to protect the ball and seats.
3. Ball valves should remain in the original shipping containers and stored indoors. End protectors should remain on the valve ends to prevent the entrance of dirt. The storage environment should be dry and not have severe swings in temperature and humidity.

10. SERVICE CONTACT

Flow-Tek Service may be reached 24 hours per day / 7 days per week.

